

W15RK3S-PTA3

15.6" ARM A72+A53 PT Series HMI Panel PC



KEY FEATURES

- 15.6" 1920 x 1080 with PCAP touchscreen
- ARM A72 + A53 Processor
- Fanless cooling system and ultra-low power consumption
- Front IP65 for protection against water and dust
- A true flat, easy-to-clean front surface with edge-to-edge design



SPECIFICATIONS

Display			
Touch / Glass	Projected Capacitive Multi Touch Screen	Resolution	1920x1080
Size	15.6 inches	Contrast Ratio	800:1
Panel Brightness	400 nits	View Angles	85,85,85,85
System Specification			
Processor	ARM A72 (up to 2.0 GHz) + ARM A53 (up to 1.5 GHz)	Memory	2GB LPDDR3L 1600 4GB (Optional)
Storage	Onboard 16GB eMMC Onboard 32GB eMMC (Optional) Micro SD Card SDHC (Optional)	Operating System	Android 7.1
Environment			
Operating Humidity	10% to 90% (non-condensing)	Operating Temperature	0~50°C
Storage Temperature	-20~60°C	IP rating	Front IP65
Certification			
Certification	CE, FCC		
Mechanical			
Dimension	388 x 233 x 40 mm	Mounting	VESA Mount (100 x 200, 100 x 100, 75 x 75 mm)
Enclosure	Plastic	Cooling System	Fanless Design
IO Ports			
USB Port	1 x USB 3.0, 1 x USB 2.0, 1 x USB OTG	Serial Port	1 x RS-232/422/485
SD Card Slot	1 x Micro SD Card Slot	Video	1 x Micro HDMI (Optional)
Audio	2 x Speaker	LAN	1 x RJ 45-10/100/1000 Mbps LAN Support PoE function
Indicator	Power LED Indicator		
Accessory			
Accessory	Driver CD & User Manual Quick Start Guide(Hardcopy) AC Adapter 12V/50W Power Cord 3 Pin Terminal Block to DC Jack		
Power			

Power Rating 12V DC in(Phoenix type) POE Power Device (PD), follows IEEE 802.3at (25 W)

Control

Button 1 x Power Button
1 x Reset Button

DIMENSIONS UNIT:MM

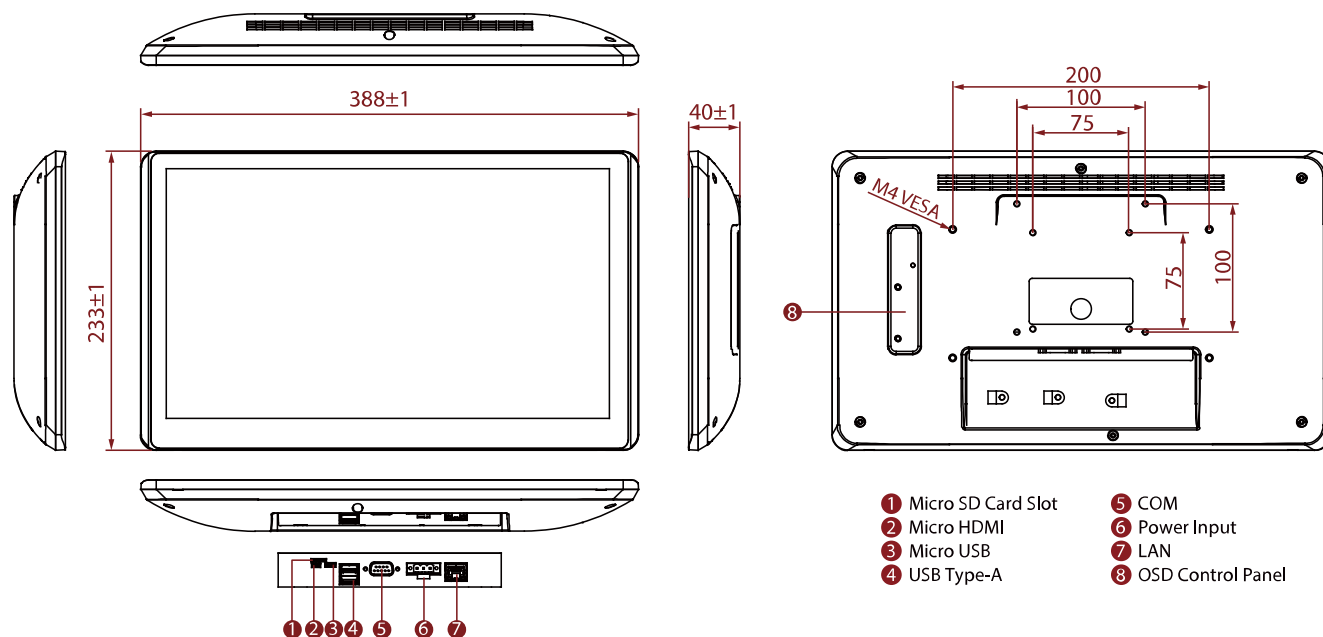

NOTE

1. This is a simplified drawing and some components are not marked in detail.
2. Please contact our sales representative if you need further product information.
3. All specifications are subject to change without prior notice.
4. The product shown in this datasheet is a standard model. For diagrams that contain customized or optional I/O, please contact the Winmate Sales Team for more information.