

MONITOR YOUR DATA CENTER WITH RARITAN'S PLUG-AND-PLAY SENSORS

SmartSensor is a comprehensive set of environmental sensors that deliver accurate data providing insights into your data center's environment. The advanced feature set allows for easy deployment, clear identification of hot spots, and better airflow management. SmartSensors models are available for monitoring temperature, humidity, airflow, air pressure, water/leaks, contact closures, proximity detection, vibration and more.

All environmental data collected by the sensor can be sent to any DCIM Monitoring software to provide a complete picture of data center conditions at the rack, aisle, and facility level. Real-time alerts of potential threats in your environment are also sent to administrators for fast resolution.

With Raritan's SmartSensors, adding environmental monitoring to your existing infrastructure is easier and more cost-effective than ever before. Setting the new standard for easy data center deployment with its plug-and-play connection to any Raritan power device including PX intelligent rack PDU series, smart rack controllers, PX inline meters, rack transfer switches, and branch circuit monitors.

PRE-INTEGRATED WITH RARITAN PX IPDUS, DCIM SOFTWARE

A seamless solution that works out-of-the-box with PX Intelligent PDUs, and Power IQ[®] DCIM monitoring software.



SMARTSENSOR BENEFITS

- Accurate monitoring of various conditions in your environment: temperate, humidity, airflow, air pressure, water leaks, and vibrations
- Save on cooling by confidently raising data center temperatures
- Check airflow and air pressure to and from racks to prevent hot spots and bypass recirculation
- Improve data center uptime by receiving environment alerts to prevent hot spots, bypass airflow and recirculation
- Make smarter rack management decisions based on factual environmental insights
- Easily install plug-and-play sensors without disrupting operations

EASY COMPLIANCE WITH ENVIRONMENTAL STANDARDS (ANSI/ASHRAE)

Environment Sensors are one of the most useful tools needed to accurately report on all critical environmental conditions impacting your IT equipment and to make decisions to comply with ASHRAE environmental standards.

SmartSensors facilitate the collection of key environmental data and provide a more efficient deployment and management experience by pushing data into any DCIM or BMS software, through the Xerus Technology platform, already built in Raritan Products.

SENSORS IN YOUR DATA CENTER



TEMPERATURE

The DX2-T1 can be placed at the front or rear of the rack to monitor cool air entering and/or hot air being expelled to ensure proper containment.¹



VIBRATION

The DX-VBR detects vibrations such as earthquakes and damaged fans, along three axes (x, y, z).



WATER/LEAK

The DPX-WSF-KIT, DPX-WSC-35-KIT, and DPX-WSC-70-KIT sensors monitor leaks on the floor, around an area, on liquid cooled racks, and can detect condensation.



CONTACT CLOSURE

DX2-CC2 dual contact closure is used with third party sensors, and integrates with data center smoke detectors to monitor risky conditions and aggregate data through Raritan Xerus Platform.



RACK INLET TEMPERATURE AND HUMIDITY

The DX2-T3H1 strings together 3 sensor heads, making it easy to mount them at the bottom, middle, and top of the cool air inlet side as per ASHRAE² guidelines.



AIRFLOW

The DPX-AF1 can meter airflow in plenum space, such as under a raised floor or just above the perforated tiles.



DIFFERENTIAL AIR PRESSURE

The DPX-T1DP1 meters differential air pressure above and below a raised floor, or between hot aisles and cold aisles to prevent thermal leaks.

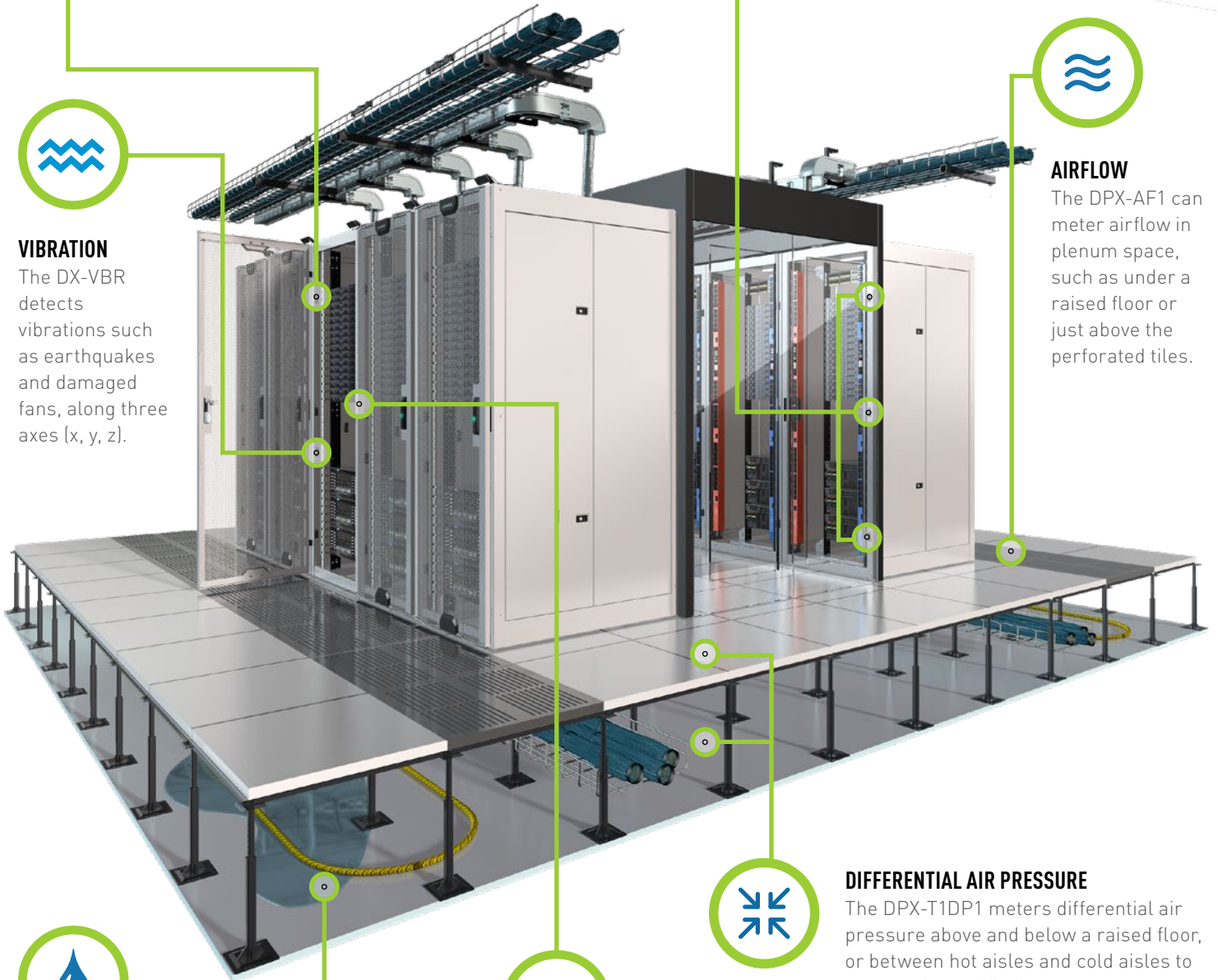

¹ Additional temperature and humidity sensor options are available.

² The American Society of Heating, Refrigerating and Air-Conditioning Engineers (ASHRAE) recommends measuring the cool air entering IT equipment near the bottom, in the middle, and near the top of each IT rack.

INNOVATIVE FEATURES

RJ45, REMOVABLE SENSOR HEADS

If sensor accuracy diminishes, you don't need to remove the entire sensor; just replace the sensor head to maintain a high degree of accuracy.



LED INDICATOR

LED light that visually alerts technicians when temperature thresholds are exceeded.

SINGLE BUS/STRING TECHNOLOGY

Offering the highest flexibility of deployment by the standard sensor cord or any Cat 5/6-type cable connection, the SmartSensor allows you to cascade up to 32 sensors through a single bus. The SmartSensor makes it easy to instrument entire rows of your data center with different types of sensors through a single control device.

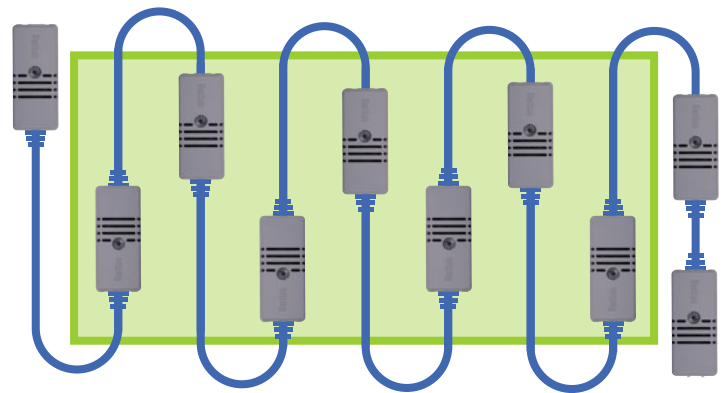

HIGH-ACCURACY AND HIGH-RELIABILITY METERING

All SmartSensors benefit from the latest, most high-tech metering components, with an MTBF of more than 20 years per sensor. SmartSensor delivers the highest metering accuracy at +/- 0.5°C for temperature sensors, +/-2.5% for relative humidity.

POWER IQ® DCIM MONITORING

Environment data collected by sensors can be instantly sent to Power IQ® DCIM monitoring software which allows you to confidently raise ambient temperatures and adjust fan speed in CRAHs and CRACs to increase your energy savings and get the most out of your cooling systems.

Additionally, users can compare the data from sensors to the environmental envelope of a psychrometric chart to ensure that adequate cooling is where it needs to be, proper operating conditions have been maintained, and that they are in compliance with corporate, vendor, or utility

Power IQ allows you to:

- See hot spots at-a-glance
- Know when to increase/decrease temperature set points
- Know how much to humidify
- Easily manage to ASHRAE standard thermal envelopes
- Simplify how you manage airside economization
- Customize and add your own thermal envelopes



Learn more at www.raritan.com/poweriq

SMARTSENSOR™ MODELS

Type of Sensor	Part Number	Description	Range	Accuracy
SmartSensor: Temperature	DX2-T1	Single temperature sensor, field replaceable sensor module, RJ-45 connector.	-20°C to 20°C 20°C to 70°C	+/- 2°C +/- 0.5°C
SmartSensor: Temperature and Humidity	DX2-T1H1	Single combo temperature and humidity sensor, field replaceable sensor modules, RJ-45 connector.	-20°C to 20°C 20°C to 70°C 0% RH to 100% RH	+/- 2°C +/- 0.5°C +/- 2.5% /RH
SmartSensor: Temperature and Humidity	DX2-T2H2	Dual combo temperature and humidity sensors, field replaceable sensor modules, RJ-45 connector.	-20°C to 20°C 20°C to 70°C 0% RH to 100% RH	+/- 2°C +/- 0.5°C +/- 2.5% /RH
SmartSensor: Temperature and Humidity	DX2-T3H1	Three temperature sensors, middle sensor supporting humidity (four sensors total in three housings), field replaceable sensor modules, RJ-45 connector.	-20°C to 20°C 20°C to 70°C 0% RH to 100% RH	+/- 2°C +/- 0.5°C +/- 2.5% /RH
SmartSensor: Airflow Management	*DX2-AF1	Single airflow sensor, RJ-45 connector.	N/R	N/R
SmartSensor: Differential Pressure	*DX2-T1DP1	Single combo differential air pressure and temperature sensor, RJ-45 connector.	N/R	N/R
SmartSensor: Contact Closure	DX2-CC2	2 Contact Closure Sensor for connection and management 3rd party sensors (Smoke, sound, etc.)	N/R	N/R
Water/Leak Sensor	DX-WSF-KIT	Floor water/leak sensor plus contact closure sensor, RJ-12 connector.	N/R	N/R
Water/Leak Sensor	DX-WSC-35-KIT	11.5ft (3.5m) rope water/leak sensor plus contact closure sensor, RJ-12 connector.	N/R	N/R
Water/Leak Sensor	DX-WSC-70-KIT	23ft (7.0m) rope water/leak sensor plus contact closure sensor, RJ-12 connector.	N/R	N/R
Vibration Sensor	DX-VBR	Vibration sensor that detects acceleration along three axes (x, y, z). RJ-45 connector.	0 to 3.64g	0.01g
*DX2 Models T1DP1 and AF1 Will Be Coming in 2019, Contact Your Raritan Representative for Availability.				

Visit www.raritan.com/SmartSensor
or Call 1.800.724.8090 for more information.

©2019 Raritan Inc. All rights reserved. Raritan® is a registered trademarks of Raritan Inc. or its wholly-owned subsidiaries. All others are registered trademarks or trademarks of their respective owners. Raritan began developing KVM switches for IT professionals to manage servers remotely in 1985. Today, as a brand of Legrand, we are a leading provider of intelligent rack PDUs. Our solutions increase the reliability and intelligence of data centers in 9 of the top 10 Fortune 500 technology companies. Learn more at Raritan.com V1191R8

Raritan
A brand of  Legrand