



Features

- Bi-directional Energy
- True RMS Power Measurements
- Energy Analysis for 3P4W, 3P3W, 1P3W, 1P2W
- Current Measurements Up to 400 A with Different CT Ratio
- Isolated Voltage Measurements Up to 600 V
- Clip-on CT for Easy Installation
- W Accuracy Better than 0.5% (PF=1)
- Total Harmonic Distortion (THD)
- RS-485, Ethernet or CAN bus communication interface
- Supports Modbus RTU, Modbus TCP, CANopen or EtherNet/IP Protocols
- IEC 61010-1 and EN 61010-1
- Multiple Data Format



Introduction

ICP DAS brings the most powerful, cost-effective, advanced Smart Power Meters PM-3133i series that gives you access to real-time electric usage for three-phase power measurement. With its high accuracy ($<0.5\%$, $PF=1$), the PM-3133i series can be applied to both low voltage primary side and/or medium/high voltage secondary side and enables the users to obtain reliable and accurate energy consumption readings from the monitored equipments in real time under operation. These compact size and cost-effective power meters are equipped with revolutionary wired clip-on CT (various types, support input current up to 400 A). It operates over a wide input voltages range 10 ~ 600 VAC which allows worldwide compatibility. Built-in AC isolator protection, this means total isolation between the AC measurement side and the control side.

Specifications

Models	PM-3133i	PM-3133i-MTCP	PM-3133i-EIP	PM-3133i-CPS
AC Power Measurement				
Wiring	3P4W-3CT, 3P3W-2CT, 3P3W-3CT, 1P2W-1CT, 1P3W-2CT			
Input Voltage	10 ~ 600 V; built-in isolation transformer			
Input Current	CTØ10 mm (0.05 A~60 A); CTØ16 mm (0.1 A~100 A); CTØ24 mm (0.15 A~200 A); CTØ36 mm (0.3 A~300 A); CTØ36 mm (0.3 A~400 A).			
Input Frequency	50 Hz (Range 45 ~ 55 Hz)/60 Hz (Range 55 ~ 65 Hz)			
W Accuracy	Better than 0.5% (PF=1)			
Power Parameter Measurement	True RMS voltage (V_{rms}), True RMS current (I_{rms}), Active Power (kW), Active Energy (kWh), Apparent Power (kVA), Apparent Energy (kVAh), Reactive Power (kVAR), Reactive Energy (kVARh), Power Factor (PF), Frequency (45 ~ 65 Hz)			
Data Update Rate	1 Second			
Communication				
RS-485	Protocol	Modbus RTU	-	-
	Baud Rate	9600,19200 (default), 38400, 115200; DIP Switch Selectable	-	-
	Data Format	N,8,1 (default); N,8,2; E,8,1; E,8,2; O,8,1; O,8,2	-	-
	Isolation	3000 Vdc	-	-
Ethernet	Protocol	-	Modbus TCP	EtherNet/IP
CAN bus	Protocol	-	-	CANopen
	Baud Rate	-	-	125 k (default), 250 k, 500 k, 1 M; DIP Switch Selectable
	Isolation	-	-	3000 VDC
Power				
Input Range	+12 ~ 48 Vdc	+12 ~ 48 Vdc or PoE		+12 ~ 48 Vdc
Power Consumption	2 W			
Environment				
Temperature	Operating Temperature: -20 ~ +70 °C / Storage Temperature: -25 ~ +80 °C			
Ambient Relative Humidity	10% ~ 90% RH, Non-condensing			

Wire Connections

When the inverter is running, it will generate some high frequency or low frequency noise, and interfere with the peripheral equipment by conduction or radiation.

It is recommended that the CT and reference voltage of the meter be installed on the primary side of the "AC Filter" with an EMI ferrite core to minimize the interference effects of the inverter.

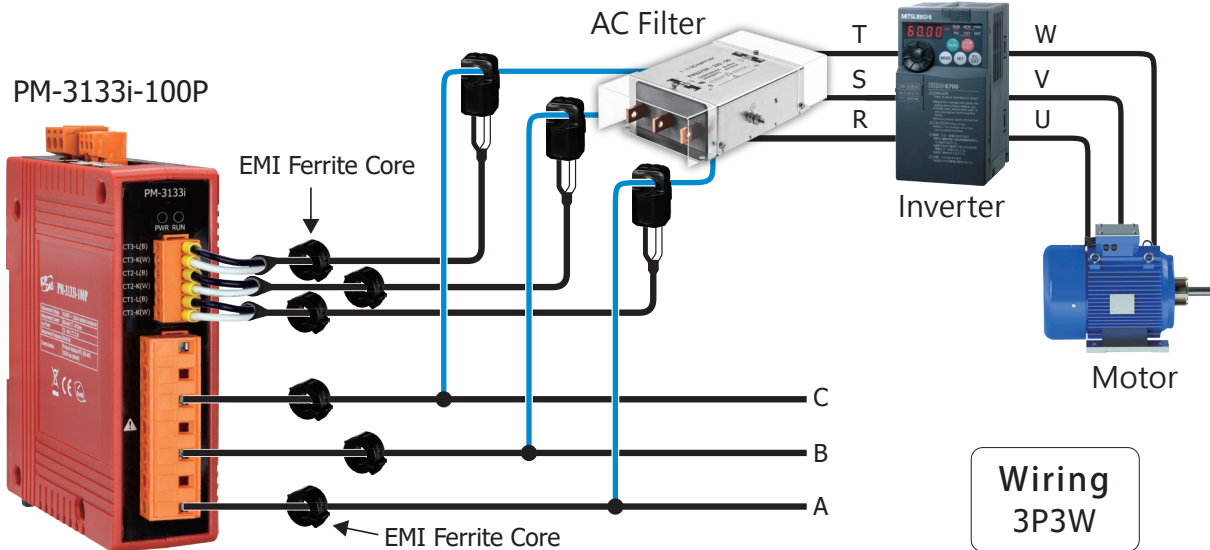

Dimensions (Units: mm)

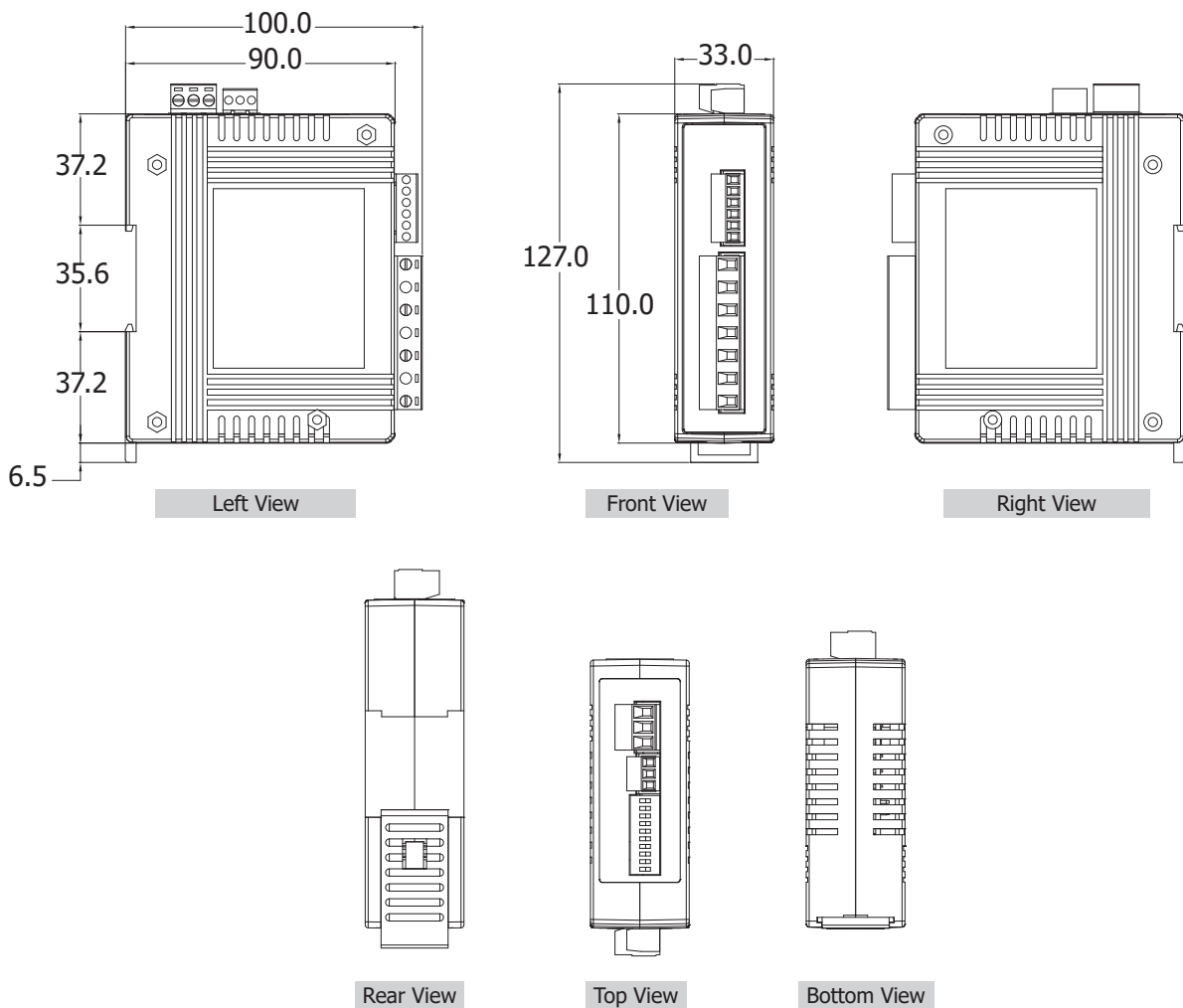

Ordering Information

RS-485 Interface	
PM-3133i-100P CR	Modbus RTU, Isolated 3-phase power meter; includes 60A CT (Inside diameter 10 mm; wire lead 4 m) x 3 (RoHS)
PM-3133i-160P CR	Modbus RTU, Isolated 3-phase power meter; includes 100A CT (Inside diameter 16 mm; wire lead 4 m) x 3 (RoHS)
PM-3133i-240P CR	Modbus RTU, Isolated 3-phase power meter; includes 200A CT (Inside diameter 24 mm; wire lead 4 m) x 3 (RoHS)
PM-3133i-360P CR	Modbus RTU, Isolated 3-phase power meter; includes 300A CT (Inside diameter 36 mm; wire lead 4 m) x 3 (RoHS)
PM-3133i-400P CR	Modbus RTU, Isolated 3-phase power meter; includes 400A CT (Inside diameter 36 mm; wire lead 4 m) x 3 (RoHS)

Ethernet Interface (Modbus TCP)	
PM-3133i-100P-MTCP CR	Modbus TCP, Isolated 3-phase power meter; includes 60A CT (Inside diameter 10 mm; wire lead 4 m) x 3 (RoHS)
PM-3133i-160P-MTCP CR	Modbus TCP, Isolated 3-phase power meter; includes 100A CT (Inside diameter 16 mm; wire lead 4 m) x 3 (RoHS)
PM-3133i-240P-MTCP CR	Modbus TCP, Isolated 3-phase power meter; includes 200A CT (Inside diameter 24 mm; wire lead 4 m) x 3 (RoHS)
PM-3133i-360P-MTCP CR	Modbus TCP, Isolated 3-phase power meter; includes 300A CT (Inside diameter 36 mm; wire lead 4 m) x 3 (RoHS)
PM-3133i-400P-MTCP CR	Modbus TCP, Isolated 3-phase power meter; includes 400A CT (Inside diameter 36 mm; wire lead 4 m) x 3 (RoHS)

Ethernet Interface (EtherNet/IP)	
PM-3133i-100P-EIP CR	EtherNet/IP, Isolated 3-phase power meter; includes 60A CT (Inside diameter 10 mm; wire lead 4 m) x 3 (RoHS)
PM-3133i-160P-EIP CR	EtherNet/IP, Isolated 3-phase power meter; includes 100A CT (Inside diameter 16 mm; wire lead 4 m) x 3 (RoHS)
PM-3133i-240P-EIP CR	EtherNet/IP, Isolated 3-phase power meter; includes 200A CT (Inside diameter 24 mm; wire lead 4 m) x 3 (RoHS)
PM-3133i-360P-EIP CR	EtherNet/IP, Isolated 3-phase power meter; includes 300A CT (Inside diameter 36 mm; wire lead 4 m) x 3 (RoHS)
PM-3133i-400P-EIP CR	EtherNet/IP, Isolated 3-phase power meter; includes 400A CT (Inside diameter 36 mm; wire lead 4 m) x 3 (RoHS)

CAN bus Interface	
PM-3133i-100P-CPS CR	CANopen, Isolated 3-phase power meter; includes 60A CT (Inside diameter 10 mm; wire lead 4 m) x 3 (RoHS)
PM-3133i-160P-CPS CR	CANopen, Isolated 3-phase power meter; includes 100A CT (Inside diameter 16 mm; wire lead 4 m) x 3 (RoHS)
PM-3133i-240P-CPS CR	CANopen, Isolated 3-phase power meter; includes 200A CT (Inside diameter 24 mm; wire lead 4 m) x 3 (RoHS)
PM-3133i-360P-CPS CR	CANopen, Isolated 3-phase power meter; includes 300A CT (Inside diameter 36 mm; wire lead 4 m) x 3 (RoHS)
PM-3133i-400P-CPS CR	CANopen, Isolated 3-phase power meter; includes 400A CT (Inside diameter 36 mm; wire lead 4 m) x 3 (RoHS)